

Gouge profile and grinding angle guides

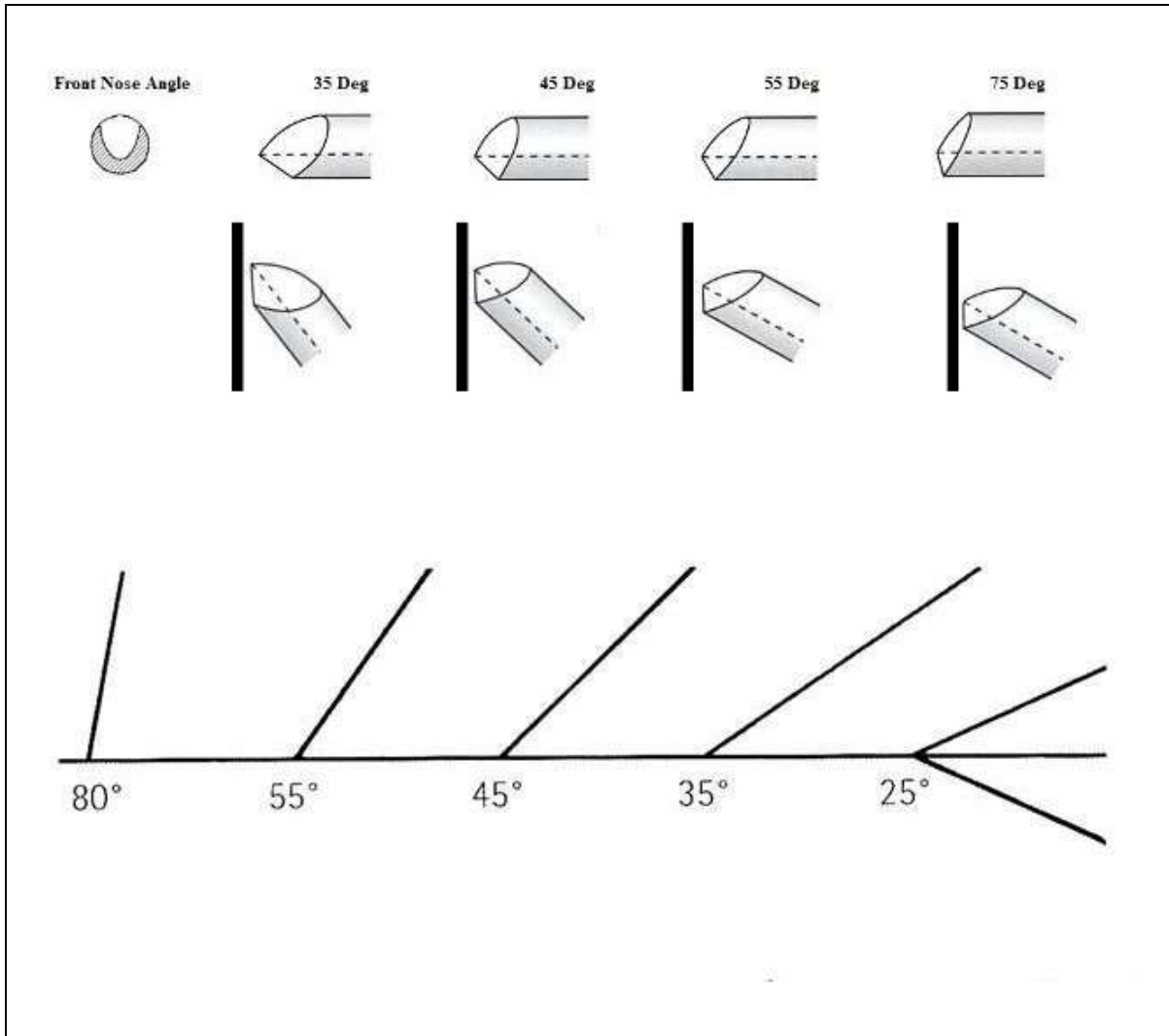

Bowl Gouge Sizing :-

USA = diameter of the bar

UK = inside of flute on one side to outside of bar on the other side →

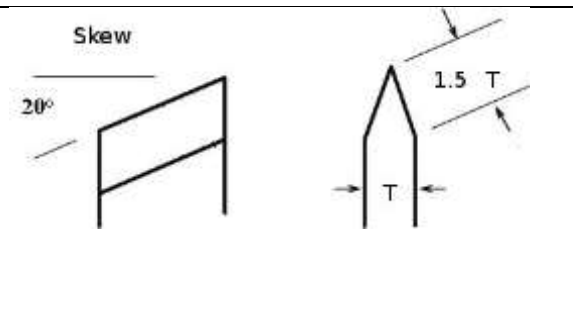
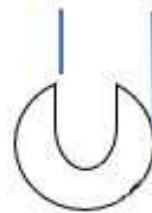

Front face 20 deg to a long edge, bevel flat width 1-1/4 to 1-1/2 the tool thickness.

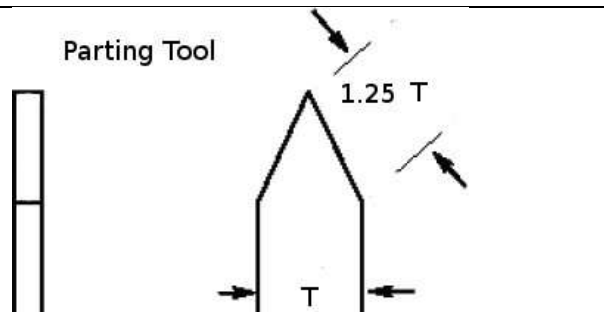

Sloped face width 1-1/4 times the blade width.



Grinder Angle Guides